

VME-IFoIP - SPC

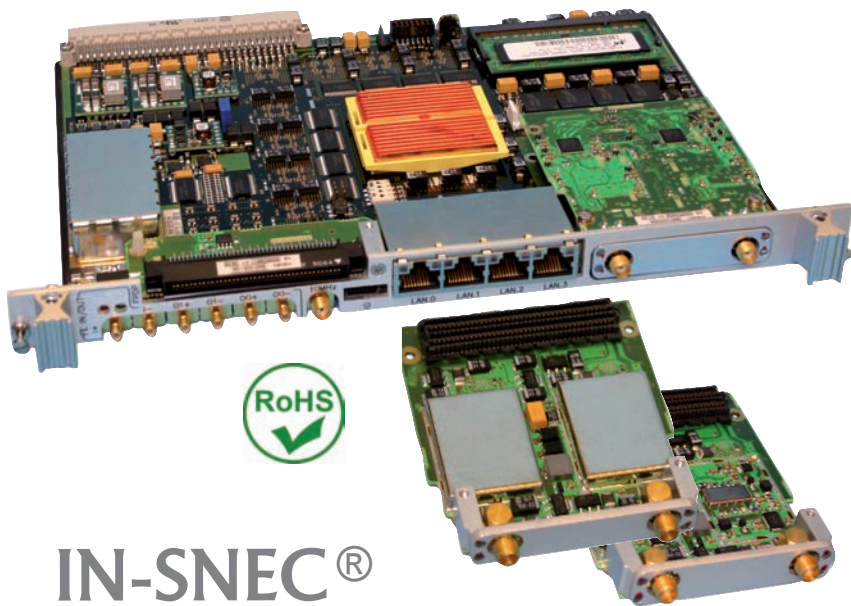

IN-SNEC®

The VME-IFoIP (Intermediate Frequency over Internet Protocol) family is composed of the following VME 6U form factor boards :

- VME-IFoIP-SPC
- VME-IFoIP-HPC

The input signal is wideband digitized with an adjustable sampling frequency, channelized, formatted, optionally processed in FPGAs. Sample flows are then routed to computer nodes over one or several LANs, using the Gigabit Ethernet interfaces. Together with the wideband acquisition board comes an easy to use library to help the users to develop their own applications.

VME-IFoIP-SPC - Standard Processing Capability Acquisition board

The VME-IFoIP-SPC wideband acquisition board is composed of one daughter board plugged on a Standard Processing Capacity mother board integrated in a VME 6U form factor within 1 slot.

This system features 2 RF analog inputs in either 70MHz or 140MHz intermediate frequency or L Band, 8 DDC, 1 Virtex-V FPGA FX100T, 4 Gigabit Ethernet.

The input signal is wideband digitized with a sampling frequency up to 186 MHz

VME-IFoIP-HPC - High Processing Capability Acquisition board

The VME-IFoIP-HPC wideband acquisition board is composed of one daughter board plugged on a High Processing Capacity mother board integrated in a VME 6U form factor within 1 slot.

This system features 2 RF analog inputs in either 70 MHz or 140 MHz intermediate frequency or L Band, up to 32 DDC, 1 Virtex-V FPGA SX240T, 4 Gigabit Ethernet.

The input signal is wideband digitized with a sampling frequency up to 186 MHz.

VME IF over IP Wideband Acquisition boards

Applications

- SDR products
- Digital communications
- Base stations
- Modems
- Wideband recording for post processing

Main Features

- 80 MHz instantaneous bandwidth
- High speed digitizer
- Wideband snapshot length up to
 - ◆ 5s for 1 input
 - ◆ 2.5s for 2 inputs
- 8 independent DDC up to 10MHz bandwidth
- Configurable RF inputs with daughter board
- API drivers

Main Benefits

- Open and evolutive architecture
- Standard interfaces
- Multiple types of RF inputs
- Modularity, powerful for small form factor
- Easy IP

Options

- Daughter boards
 - ◆ IF=70MHz
 - ◆ IF=140MHz
 - ◆ L band

ZODIAC DATA SYSTEMS

AEROSAFETY & TECHNOLOGY
Telemetry & Telecommunications

ZODIAC
AEROSPACE 

Modele references

IFoIP SPC / Plug IF70	SM01028764A
IFoIP SPC / Plug IF140	SM01028765A
IFoIP SPC / Plug L Band	SM01028766A

VME-IFoIP - SPC

SPC mother board (*Standard Processing Capability)

WB channelizing	
Snapshot length	> 5 s for maximum bandwidth
NB channelizing	
Technique	Digital Down Converter
Channels quantity	8
Maximum BW	Plug sampling frequency/8
Minimum BW	Plug sampling frequency/2000
Processing	
DDC	DDC with CIC 5 stage and up to 512 coefficients for filter (FIR)
FPGA type	XILINX V5
Datation	Yes (on master clock)/ 1pps
Synchronization	Internal / External (10 MHz)
Data transfer	
Mode	Data flow de-interleaving
Implementation	4 Gigabits Ethernet ports
Control	Protocol TCP/IP
Samples transfer	Protocol UDP/IP
Digital interfaces	
FPDP	Yes
I/O	Yes

Application example

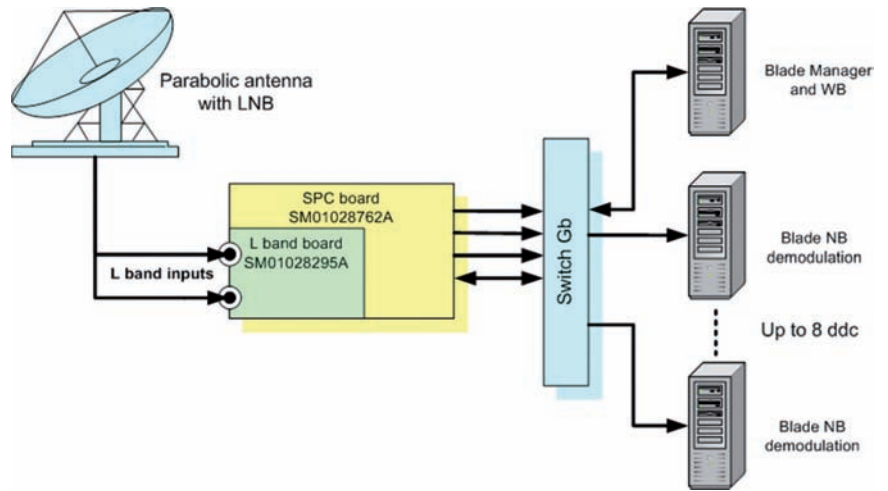

Mechanical characteristics

Weight	<1.5 lb (< 500 g)			
Dimensions	VME form factor (6Ux1 slot)			
Power consumption	≤ 35W			
Temperature	operating	0 to +40°C	storage	-40 to +70°C
Relative humidity	operating	0 to +85%	storage	0 to +95%

IF=70 MHz daughter board

Analog inputs

Input quantity	2
IF signal	70 MHz maximum bandwidth 46 MHz
IF filter	SAW filter, BW@3dB = 40 MHz
Input level	Max +10 dBm
Gain /dynamic /step	26 dB /30 dB /1 dB
Noise factor	12 dB@Gmax
Level control facilities	yes

Analog to Digital conversion

Sampling frequency	93,3 MHz
ADC resolution	12 bits
SINAD	10.7 bits

Interfaces

Form factor	FMC
Connector	FMC male

IF=140 MHz daughter board

Analog inputs

Input quantity	2
IF signal	140 MHz max. bandwidth 93 MHz
IF filter	SAW filter, BW@3dB = 80 MHz
Input level	Max +10 dBm
Gain /dynamic /step	23 dB /30 dB /1 dB
Noise factor	12 dB@Gmax
Level control facilities	yes

Analog to Digital conversion

Sampling frequency	186.6 MHz
ADC resolution	12 bits
SINAD	10.3 bits

Interfaces

Form factor	FMC
Connector	FMC male

L band daughter board

Analog inputs

Input quantity	2
RF signal	925 to 2175 MHz tunable
RF filter	Low pass filter, BW@0.5dB = 80 MHz
Input level	Max +0 dBm
Gain /dynamic /step	60 dB / 75 dB / 1 dB
Noise factor	17 dB@Gmax
Level control facilities	yes (automatic, manual)

Analog to Digital conversion

Sampling frequency	120 x 2 MHz I,Q
ADC resolution	14 bits
SINAD	> 10 bits on I and Q channel
SFDR	> 45dBc
Instantaneous dynamic	up to 31 dB in 80 MHz BW

Interfaces

Form factor	FMC
Connector	FMC male

ZODIAC DATA SYSTEMS

Aérodrome d'Arcachon
33260 La Teste - FRANCE
Tel. +33 (0)5 57 52 76 30

2 rue de Caen
14740 Bretteville l'Orgueilleuse - FRANCE
Tel. +33 (0)2 31 29 49 49

5 avenue des Andes
91978 Courtaboeuf - FRANCE
Tel. +33 (0)1 69 82 78 00

3 avenue du Canada
91966 Courtaboeuf - FRANCE
Tel. +33 (0)1 64 86 34 00

contact_zds-fr@zodiacaerospace.com

www.zds-fr.com