

Cortex RTR-XL - Radio Telemetry Receiver

A cost-effective and high performance COTS solution for a ground receiving station



IN-SNEC®

CORTEX Series

The Cortex RTR-XL, based on the famous Cortex architecture, is the latest COTS integrated telemetry receiver from ZODIAC DATA SYSTEMS, founded on over 40 years experience in equipment and systems for flight test telemetry.

Thanks to its powerful front end, the Cortex RTR-XL can manage a dual channel wideband transmissions in P, L, S and C bands, featuring a TIER compatible phase noise and an outstanding 110dB-dynamic linear AGC. Not only the FPGA-based architecture offers a versatile and reliable digital processing (IF filtering, optimal pre-D and post-D combinations, multimode demodulations, bit and frame synchronizers, FEC decoders) but it empowers the user with a long-term provision for supporting higher bit rates, new demodulation and much more just through simple user-made on-site software upgrades.

Besides, spare PCI slots can be used for any future hardware upgrades like the accommodation of a C-band module to manage softly and cost efficiently the S to C-band moving or of any customer tailored solution when specific RF band is requested.

The Cortex RTR-XL is today acclaimed worldwide as the most advanced digital telemetry receiver with an **All-in-1-box solution** minimizing room and cabling interfaces while increasing versatility and performances.

As a consequence, since 2002, more than 500 Cortex RTR-XL have been selected by the most demanding flight test customers from governmental test ranges, aircraft manufacturers, integrators and space agencies.

**Cutting-edge
Multi-h CPM**

Main Features

- Single or dual channels P/L/S/C band (fully independent)
- Single or dual 70MHz IF inputs
- IRIG 106-XX compliant
- Excellent phase noise compatible with TIER 2
- Optimum ratio Pre-D combiner (freq. / polar. Diversity)
- Fully programmable multi-mode demodulator: ...PSK, PM, TIER 0,1,2 (PCM-FM, SOQPSK, Multi-h CPM)
- Versatile functions, upgradeable application
- AM demodulation for monopulse tracking
- Automatic Frequency Control (AFC)
- TCP-IP socket, Windows environment
- Compact design for complete application
- TFT color screen and built-in keyboard
- Remote Monitoring & Control (M&C) using Ethernet link, with multi-receivers configuration
- Embedded bit and frame synchronizers
- Decoders : FEC (Viterbi, ...), Reed Solomon, ...
- Built - in auto-test, debug facilities
- Built - in spectrum viewer
- Up to 40 Mbps bit rate (SOQPSK)
- 100% in-house designed product

Main Benefits

- User-friendly and intuitive GUI over Windows XP/W2000 OS
- High integration with drastically reduced hardware for increased availability
- Enhanced performances, upgradeability and flexibility due to extensive use of Digital Signal Processing techniques
- No tuning, no preventive maintenance
- RF design performances better than IRIG106
- Quad-band (P, L, S, C) receiver
- Fast diagnostic & assistance

ZODIAC DATA SYSTEMS

AEROSAFETY & TECHNOLOGY
Telemetry & Telecommunications

**ZODIAC
AEROSPACE** 

Technical specifications

Radio

Frequency range (and/or)	
C-band	4400-5250 MHz
S-band	2180-2485 MHz
Upper L-band	1710-1850 MHz
Lower L-band	1429-1545 MHz
Special L-band	830- 1130 MHz
P-band	200 – 500 MHz
Dynamic range	-10 dBm to noise threshold
Frequency accuracy	± 1 ppm
Noise figure	< 12 dB (8 dB typ.)
Spurious signal rejection	> 60 dBc
RF input	50 Ω, VSWR < 2:1
IF analog filters	8 pre-selection SAW filters with automatic selection from 500kHz to 36MHz
Non destructive input level	+10 dBm

Signal processing

AFC	Acquisition range up to ± 250 kHz
IF filters	30 FIR digital filters (3kHz to 36MHz)
AGC modes	Automatic / Manual / Freeze
AGC time constant	0.1 to 1000 ms
AM response	from AGC cut-off to 50 kHz
Demodulation	FM, PM, AM (auto-tracking), BPSK, QPSK, AQPSK, OQPSK, SOQPSK, FQPSK, Multi symbol FM, sub carriers: FM/FM, PM/BPSK
Video filtering	17 digital filters (12.5 kHz to 20 MHz)
PCM codes	NRZ-L/M/S, BP-L/M/S, DM-M/S, differential, others...
Bit rates (max)	PCM/FM 30 Mbps QPSK 20 Mbps SOQPSK 40 Mbps Multi-h CPM 24 Mbps
De-emphasis (TV)	CCIR 405-1 525 or 625 lines
Pre-D tape recording & playback	from 5 kHz to 10 MHz
Decoders (CCSDS)	Viterbi (7, 1/2) Reed Solomon (223,255)

Miscellaneous

M&C	local or distant PC (via TCP-IP)
ACU software embedded	
Rackable chassis	19-inch, 4 U, D=550mm Industrial or blind version
Operating temperature	+10°C to +40°C
Storage temperature	-40°C to +70°C
Power supply	100-240 VAC, 50-60 Hz

Cortex RTR-XL

Interfaces

RF inputs	2 (N type female connector)
IF I/Os	3 outputs (to IF recorder RSR), 2 inputs (from IF recorder RSR), BNC, 50 Ω
Video/tape outputs	6 BNC outputs, low/50 Ω/ 75 Ω impedance
Video/tape levels	≤ 4 Vpp, reverse polarity, AC/DC
Video/tape bandwidth	DC to 20 MHz
Video data	separate channel, pre-D or post-D
Tape inputs	2 BNC inputs (up converters)
User outputs	7 BNC outputs (AGC, AFC, AM, Doppler...)
Bit Synch. Outputs	8 BNC, data + clock (TTL, RS422)
Reference I/O	BNC, 5/10 MHz sinewave
Test points	AGC level, AFC drift, SNR estimation, Doppler...

Combiner

Diversity modes	Polarisation (or space) Frequency
Combiner types	Pre-D 2 channels Post-D 2 channels Post-D 4 channels using 2 receivers
Modes	Optimum ratio with automatic switching to Best Source Selector Best channel
Pre-D gain	> 2.5 dB for two identical SNR

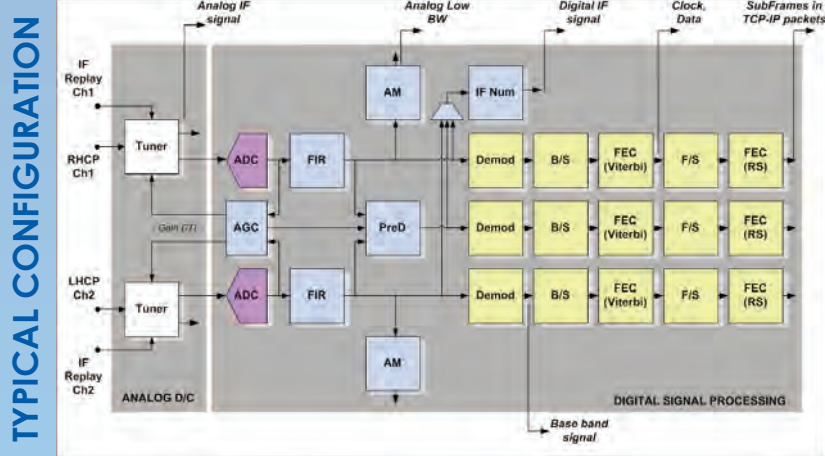

NEW DEVELOPMENTS

- ▶ ARTM TIER II Multi-h CPM : 100% in-house & optimized
- ▶ Equalization solution against multipath
- ▶ Turbo Product Decoder embedded in the RTR for improved transmission
- ▶ Quad-channel receiver in a 4U chassis
- ▶ C-band tuner and down-conversion board for US & RoW application

ZODIAC DATA SYSTEMS

Aérodrome d'Arcachon
33260 La Teste - FRANCE
Tel. +33 (0)5 57 52 76 30

2 rue de Caen
14740 Bretteville l'Orgueilleuse - FRANCE
Tel. +33 (0)2 31 29 49 49

5 avenue des Andes
91943 Les Ulis - FRANCE
Tel. +33 (0)1 69 82 78 00

3 avenue du Canada
91940 Les Ulis - FRANCE
Tel. +33 (0)1 64 86 34 00

contact_zds-fr@zodiac aerospace.com - <http://www.zds-fr.com>

www.zds-fr.com

Z.D.S. reserves the right to change specifications without notice - FFP079.5.2